



Fixing Instructions

Hockwold Towel Rail



Please unpack your delivery carefully and inspect the radiator and contents – any damages or shortages must be notified to your supplier **within 3 days of delivery** of your goods.

Specifications

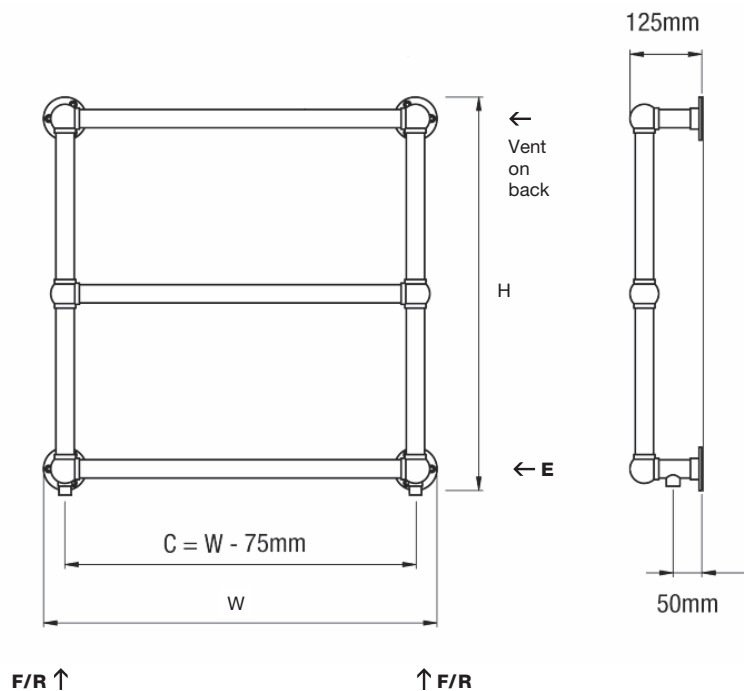

Technical Information

Standard connections: $\frac{1}{2}$ "

F = Flow **R** = Return

E = Element Position

Tube Diameter = 31.8mm

Technical Specifications

Materials: Brass

Connections: $\frac{1}{2}$ " Flow and Return

Test pressure: 7 Bar

Testing authority: EN442

Max operation pressure: 4 Bar

Max working temperature: 95c

These can be cleaned using a soft damp cloth with a non-abrasive cleaning product.



PLEASE NOTE: That in accordance with Part L1 2006 of the Building Regulations and BS7593:1992 code of practice for the treatment of hot water and central heating systems, we recommend flushing the heating system before installation of new radiators and then adding the correct quantity and type of inhibitor for use with the radiator and system to prevent corrosion. Damage caused to systems not protected by a suitable inhibitor will not be covered by the manufacturer warranty. It is the responsibility of the installer to ensure the correct use and suitability of the fixings provided. No liability for costs or damages arising from failure to do so can be accepted.

Installation Instructions



Review instructions carefully before installation.

Installation should be completed by a suitably qualified person.

Please dispose of packaging in a responsible manner.

Inside your accessories box you will have fixing screws.

Offer the towel rail to the desired position, ensuring it is level.

Mark through the holes of the base plates, then using a suitable drill bit drill holes in the desired positions. Install the correct plugs and secure the rail using the screws provided.

If you are fixing your radiator to a stud wall you should place the radiators in the desired position and hold up the back plate in position and mark through the fixing holes.

When all the brackets or feet positions are marked and/or fixed then the radiator is placed in its final position for the valve and pipe work connections.

Terms and Conditions

You must immediately remove all packaging, inspect the goods and notify us of any damage to the goods within 3 days of delivery. We shall have no obligation to replace or repair damaged goods in the event of failure by the Buyer to comply with this provision. Radiators which are off an unacceptable standard or are damaged must not be installed. If any items is installed it will be treated as being as accepted as received.

Damaged goods being returned will only be collected from your delivery address, unless otherwise agreed in writing. Any other goods, which we accept back, are to be returned by you to our place of business at your expense.

Items will be accepted as a return which have not been installed or damaged after delivery. We do not accept liability for any damages sustained after delivery. Goods should be returned in their original packaging, provided such packaging and goods are undamaged.

We may issue a credit note for goods which we accept as returned.

We may agree to provide you with replacement goods prior to collecting or receiving back the goods to be returned (whether faulty, damaged or otherwise) but only on the condition that: the replacement goods are paid for in full and we reserve the right to re-invoice you in the event that the returned goods are found to be in a worse condition than when they were originally received by you or where such goods have not been received back to us within 3 months of the replacement goods being received by yourselves. A re-stocking charge of 30% will be applied to all non-faulty stock items that wish to be returned. Special order and non-stock products cannot be cancelled. Where cancellation or alteration of orders is accepted by us, you may be required to pay a restocking charge, to cover administrative costs and collection costs (if applicable); such charges to be determined by us. If the goods we deliver are faulty or damaged, we will meet the cost of the return, as long as the fault is reported to us within 3 working days.

The goods will be deemed to have been accepted when they have been delivered and we may not accept claims for any visible defects found after installation.

We accept no liability for any cost incurred relating to the cost of installation.

We shall not be liable for any plumber's costs, decorator's costs, transport costs, late penalties, or any other costs, as a direct or indirect result of (i) any defect in the goods (including but not limited to any manufacturing faults, such as leaks, that become apparent on or after installation) or (ii) late delivery of the goods.

GUARANTEES AND LIABILITIES – we are not the manufacturer of this product we will take all reasonable endeavours to make over to you the benefit of any warranty or guarantee given by the manufacturers. The item must have been fitted in accordance with British and or European standards as well as these fitting instructions.

