



## Fixing Instructions

### Galena Horizontal Radiator



Please unpack your delivery carefully and inspect the radiator and contents – any damages or shortages must be notified to your supplier **within 3 days of delivery** of your goods.

# Specifications

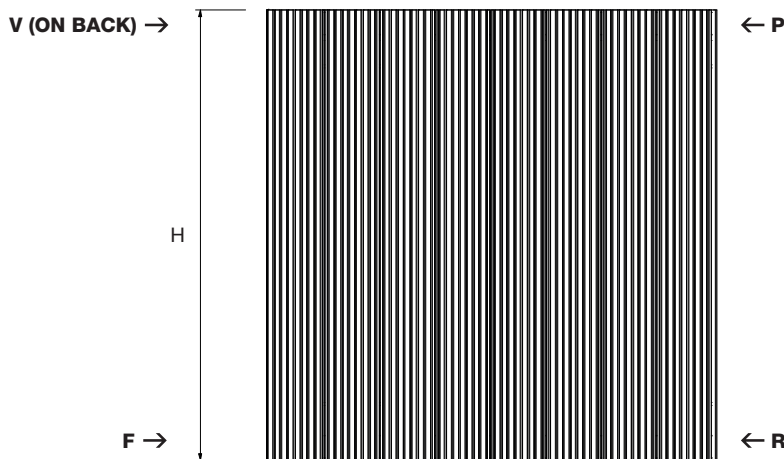
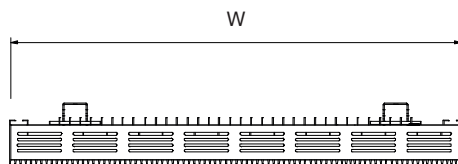
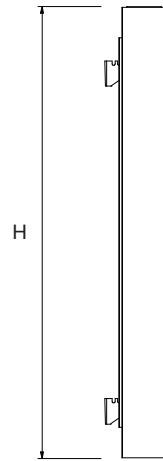

## Technical Information

**Standard connections:** ½"

**F** = Flow    **R** = Return

**P** = Plug    **V** = Vent

**Wall to front face** = 103mm

**Wall to pipe centre** = 70mm

## Technical Specifications

**Materials:** Aluminium

**Connections:** ½" Flow and Return

**Test pressure:** 8 Bar

**Testing authority:** EN442

**Max operation pressure:** 4 Bar

**Max working temperature:** 95c

These can be cleaned using a soft damp cloth with a non-abrasive cleaning product.



**PLEASE NOTE:** That in accordance with Part L1 2006 of the Building Regulations and BS7593:1992 code of practice for the treatment of hot water and central heating systems, we recommend flushing the heating system before installation of new radiators and then adding the correct quantity and type of inhibitor for use with the radiator and system to prevent corrosion. Damage caused to systems not protected by a suitable inhibitor will not be covered by the manufacturer warranty. It is the responsibility of the installer to ensure the correct use and suitability of the fixings provided. No liability for costs or damages arising from failure to do so can be accepted.

# Content list & Tools required



Review instructions carefully before installation.

Installation should be completed by a suitably qualified person.

Please dispose of packaging in a responsible manner.

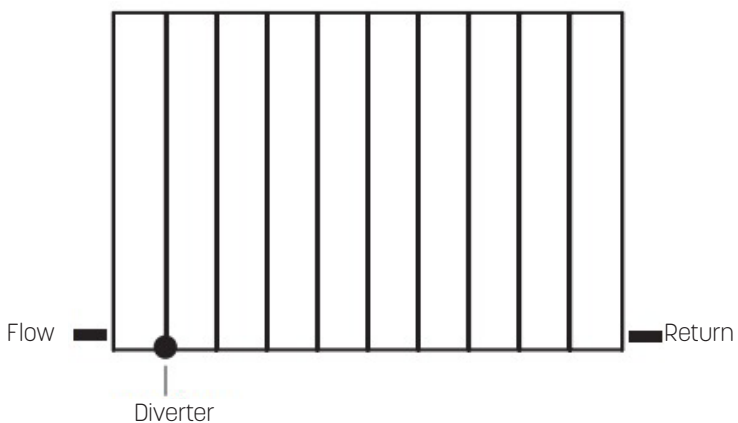

\* The diverter has been inserted into Galena radiators.

## Contents list

Ref	Icon	Description	Qty
1		Dowel	8
2		Bracket	4
3		Screw and Stamp	8

# Usage Instructions

---

Installation and assembly of heating systems should be only carried out by certificated and competent people in accordance with the standards specifying the installation principles and the rules that are stated in the assembly guideline. Installers are obliged to take all kinds of work safety and security measures against probable risks.

Our heating systems have been produced to be used in closed circuit warm water installations. They should not be connected sources other than closed circuit warm water installation.

In the heating system, absolutely don't use waters with hardness that is higher than 25 Fr or acidic or corrosive waters, PH values of which are outside the range of (6,5 - 8). Corrosive and acidic waters can give damage to your heating system and they can cause for your product to be outside the guarantee scope.

Before assembling the heating system to the installment, clean all probable construction remains or chemical materials that can be in the installment. This kind of materials that can be present in the installment can give damage to the water channels of device or they can cause them not to operate properly by blocking them. This kind of a failure can cause for your product to be outside the guarantee scope.

Heating system has been tested under 13 bar pressure and maximum operating pressure is 10 bar. It should not be used at higher pressure levels. Problems that can arise as a result of not using pressure reducers for installments with values higher than 10 bar, can cause for your product to be outside the guarantee scope.

In electrical models for safety of lives and properties, it is required for the installment to be earthed against electrical leakages. Its being used without realizing earthing can cause serious risks and for your product to be outside the guarantee scope.

All the parts that are required for the assembly of your product are provided within a box. Please check that all the parts and quantities being specified in the assembly guideline are complete.

Control that warm water entrance and exit connections of device are correct. Connection types that don't comply with installation rules avoid operation of device.

Follow up the steps on assembly pictures and make sure that external apparatus is firmly connected to the wall. After hanging the device, be careful to see whether it is on the scales or not. If there is sloping, some sections will not be heated and this will avoid for the device to operate with full efficiency.

For maximum safety and long-lasting usage, before using the system, it should absolutely be cleaned with chemical cleaning products that comply with international or TSE standards. Control the product dosage to be used carefully as per the quantities being specified on the product guideline. After the system is cleaned, it is required for the product to be operated by adding corrosion (rust) inhibitors that comply with international or TSE standards (Control the product dosage to be used carefully as per the quantities being stated on the product guideline).

# Usage Instructions

---

In the central system models, after completing the assembly by making the first water filling into the installation, empty all the water after 5 minutes of water cycle and ensure that all the construction and installation remains have been removed from the installment.

For maximum safety and long-lasting usage, before using the system it should absolutely be cleaned with chemical cleaning products that comply with international or TSE standards. (Control the product dosage to be used carefully as per the quantities that are specified on the product guideline.) After the system is cleaned, it is required for the product to be operated by adding corrosion (rust) inhibitors that comply with international or TSE standards (Control the product dosage to be used carefully as per the quantities being stated on the product guideline).

Additional precautions may be required at regions where there is limy water. Water that can be chemically softened should not be used. This is a standard precaution for all watery systems that are specified in TS EN 442, TS 226 and relevant regulations as well as BS 7593:2006. All kinds of failures that can arise as a result of not realizing chemical cleaning and not using rust inhibitors, can cause for the product to be outside the guarantee scope.

By filling the installment with water, heat the device. After the installment cycle, empty the air that has remained inside by means of air relief cock which is at the top corner of the device. Repeating the air releasing process during the next few heating processes can provide efficient operations. If water flow sound comes from inside the device, it means that air has remained inside. In this situation, repeat the air releasing process.

Maximum operating temperature of device is 95C0. Whether the device is operating or not, do not make it be exposed to conditions that could cause for the water inside to get frozen. Freezing of water gives damage to the device and damages occurring as a result of freezing are outside the guarantee scope.

After realizing full operation, DO NOT EMPTY THE WATER INSIDE THE DEVICE UNLESS REQUIRED! If it is emptied, in order to operate the device again, cleaning of device should be made by using chemical cleaning products that comply with international or TSE standards. (Control the product dosage to be used carefully as per the quantities being stated on the product guideline.)

After the system is cleaned, it is required for the product to be operated by adding corrosion (rust) inhibitors that comply with international or TSE standards (Control the product dosage to be used carefully as per the quantities being stated on the product guideline).

While cleaning the device, use a cloth that has moist and soft surface. Do not use mechanical or chemical abrasive substances (such as bleach or hydrochloric acid). If you use a different material, in order to test whether it gives damage to the surface or not, use it after applying and trying it on an unseen part of the product.

Do not add any chemical materials which are not approved as per national and international standards to the installation system (such as inhibitors, anti-freeze, pH regulator, lime and bacteria inhibitors, chemicals which are asserted to improve heat efficiency). Or else your device will be outside the guarantee scope.

# Guarantee Conditions

---

Our heating systems have been produced as per TS EN 442, CE and UK standards. Our heating systems are under guarantee scope of 5 years against production and material failures when assembly, maintenance and usage rules are complied with.

By getting approval for the guarantee certificate of your device from your seller, keep it during the guarantee period together with its invoice. Guarantee period starts on the date when invoiced product is delivered to the user.

In addition to the conditions being stated on the usage instructions;

Other than the conditions being specified on the instructions, failure notifications with reasons relating with assembly, usage, and maintenance are outside the guarantee scope.

Defects and failures originating from parts and installment being connected to the device are outside the guarantee scope.

Any damages occurring due to reasons such as falling, having dashes, being scratched or due to chemical reasons during the carriage, maintenance, assembly or usage of device are outside the guarantee scope.

# Installation Instructions

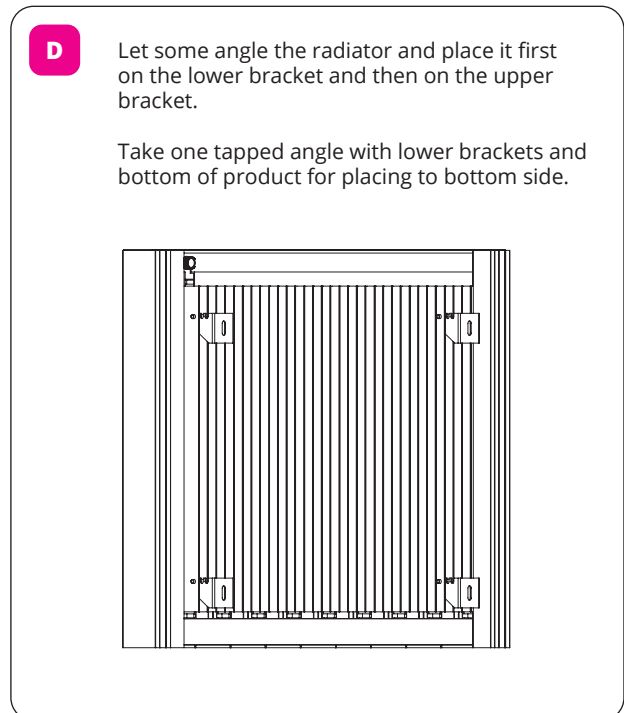
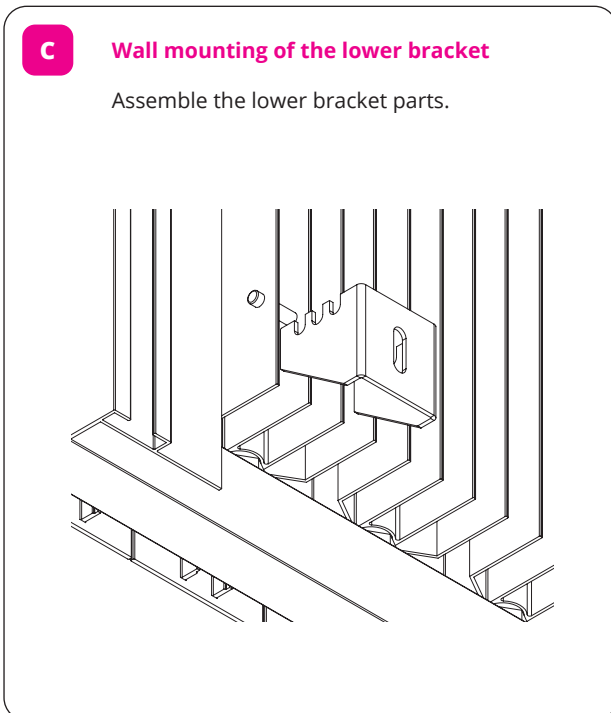
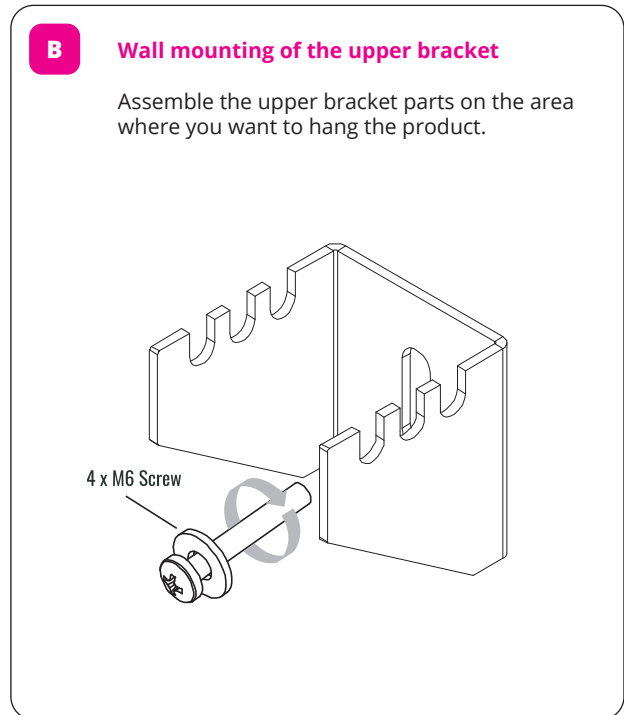
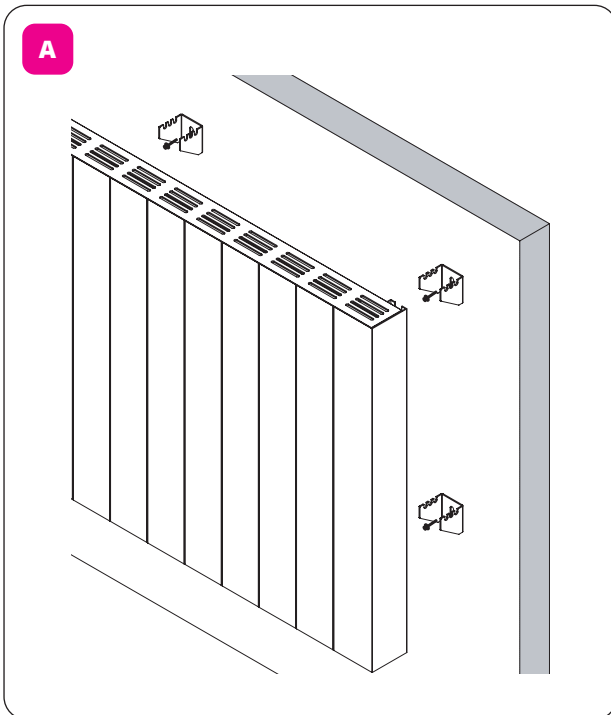

Make sure that wall connections are safe to carry to product safely. If water connection elements are compressed too much during assembly, damages causing water leakages can occur. Make sure that necessary precautions have been taken to avoid for the product to be damaged during carriage and assembly.

# Terms and Conditions

---

You must immediately remove all packaging, inspect the goods and notify us of any damage to the goods within 3 days of delivery. We shall have no obligation to replace or repair damaged goods in the event of failure by the Buyer to comply with this provision. Radiators which are off an unacceptable standard or are damaged must not be installed. If any items is installed it will be treated as being as accepted as received.

Damaged goods being returned will only be collected from your delivery address, unless otherwise agreed in writing. Any other goods, which we accept back, are to be returned by you to our place of business at your expense.

Items will be accepted as a return which have not been installed or damaged after delivery. We do not accept liability for any damages sustained after delivery. Goods should be returned in their original packaging, provided such packaging and goods are undamaged.

We may issue a credit note for goods which we accept as returned.

We may agree to provide you with replacement goods prior to collecting or receiving back the goods to be returned (whether faulty, damaged or otherwise) but only on the condition that: the replacement goods are paid for in full and we reserve the right to re-invoice you in the event that the returned goods are found to be in a worse condition than when they were originally received by you or where such goods have not been received back to us within 3 months of the replacement goods being received by yourselves. A re-stocking charge of 30% will be applied to all non-faulty stock items that wish to be returned. Special order and non-stock products cannot be cancelled. Where cancellation or alteration of orders is accepted by us, you may be required to pay a restocking charge, to cover administrative costs and collection costs (if applicable); such charges to be determined by us. If the goods we deliver are faulty or damaged, we will meet the cost of the return, as long as the fault is reported to us within 3 working days.

The goods will be deemed to have been accepted when they have been delivered and we may not accept claims for any visible defects found after installation.

We accept no liability for any cost incurred relating to the cost of installation.

We shall not be liable for any plumber's costs, decorator's costs, transport costs, late penalties, or any other costs, as a direct or indirect result of (i) any defect in the goods (including but not limited to any manufacturing faults, such as leaks, that become apparent on or after installation) or (ii) late delivery of the goods.

**GUARANTEES AND LIABILITIES** – we are not the manufacturer of this product we will take all reasonable endeavours to make over to you the benefit of any warranty or guarantee given by the manufacturers. The item must have been fitted in accordance with British and or European standards as well as these fitting instructions.

