

THANK YOU

FOR CHOOSING OUR PRODUCT

Our Radiators and Towel Rails have been designed and manufactured in such a way to ensure that all quality and aesthetic requirements are met.

This book includes: Installation and Operating Instructions.

USAGE INSTRUCTIONS

- Installation and assembly of heating systems should be only carried out by certificated and competent people in accordance with the standards specifying the installation principles and the rules that are stated in the assembly guideline. Installers are obliged to take all kinds of work safety and security measures against probable risks.
- Our heating systems have been produced to be used in closed circuit warm water installations. They should not be connected sources other than closed circuit warm water installation.
- In the heating system, absolutely don't use waters with hardness that is higher than 25 Fr or acidic or corrosive waters, PH values of which are outside the range of (6,5 - 8). Corrosive and acidic waters can give damage to your heating system and they can cause for your product to be outside the guarantee scope.
- Before assembling the heating system to the installment, clean all probable construction remains or chemical materials that can be in the installment. This kind of materials that can be present in the installment can give damage to the water
- channels of device or they can cause them not to operate properly by blocking them. This kind of a failure can cause for your product to be outside the guarantee scope.
- Heating system has been tested under 13 bar pressure and maximum operating pressure is 10 bar. It should not be used at higher pressure levels. Problems that can arise as a result of not using pressure reducers for installments with values higher than 10 bar can cause for your product to be outside the guarantee scope.
- In electrical models for safety of lives and properties, it is required for the installment to be earthed against electrical leakages. Its being used without realizing earthing can cause serious risks and for your product to be outside the guarantee scope.
- All the parts that are required for the assembly of your product are provided within a box. Please check that all the parts and quantities being specified in the assembly guideline are complete.
- Control that warm water entrance and exit connections of device are correct. Connection types that don't comply with installation rules avoid operation of device.
- Follow up the steps on assembly pictures and make sure that external apparatus is firmly connected to the wall. After hanging the device, be careful to see whether it is on the scales or not. If there is sloping, some sections will not be heated and this will avoid for the device to operate with full efficiency.
- For maximum safety and long-lasting usage, before using the system, it should absolutely be cleaned with chemical cleaning products that comply with international or TSE standards. Control the product dosage to be used carefully as per the quantities being specified on the product guideline. After the system is cleaned, it is required for the product to be operated by adding corrosion (rust) inhibitors that comply with international or TSE standards (Control the product dosage to be used carefully as per the quantities being stated on the product guideline).

01

02

USAGE INSTRUCTIONS

- In the central system models, after completing the assembly by making the first water filling into the installation, empty all the water after 5 minutes of water cycle and ensure that all the construction and installation remains have been removed from the installment.
- For maximum safety and long-lasting usage, before using the system it should absolutely be cleaned with chemical cleaning products that comply with international or TSE standards. (Control the product dosage to be used carefully as per the quantities that are specified on the product guideline.) After the system is cleaned, it is required for the product to be operated by adding corrosion (rust) inhibitors that comply with international or TSE standards (Control the product dosage to be used carefully as per the quantities being specified on the product guideline).
- Additional precautions may be required at regions where there is limy water. Water that can be chemically softened should not be used. This is a standard precaution for all watery systems that are specified in TS EN 442, TS 226 and relevant regulations as well as BS 7593:2006. All kinds of failures that can arise as a result of not realizing chemical cleaning and not using rust inhibitors, can cause for the product to be outside the guarantee scope.
- By filling the installment with water, heat the device. After the installment cycle, empty the air that has remained inside by means of air relief cock which is at the top corner of the device. Repeating the air releasing process during the next few heating processes can provide efficient operations. If water flow sound comes from inside the device, it means that air has remained inside. In this situation, repeat the air releasing process.
- Maximum operating temperature of device is 95CO. Whether the device is operating or not, do not make it be exposed to conditions that could cause for the water inside to get frozen. Freezing of water gives damage to the device and damages occurring as a result of freezing are outside the guarantee scope.
- After realizing full operation, DO NOT EMPTY THE WATER INSIDE THE DEVICE UNLESS REQUIRED! If it is emptied, in order to operate the device again, cleaning of device should be made by using chemical cleaning products that comply with international or TSE standards. (Control the product dosage to be used carefully as per the quantities being stated on the product guideline.)
- After the system is cleaned, it is required for the product to be operated by adding corrosion (rust) inhibitors that comply with international or TSE standards (Control the product dosage to be used carefully as per the quantities being stated on the product guideline).
- While cleaning the device, use a cloth that has moist and soft surface. Do not use mechanical or abrasive substances (such as bleach or hydrochloric acid). If you use a different material, in order to test whether it gives damage to the surface or not, use it after applying and trying it on an unseen part of the product.
- Do not add any chemical materials which are not approved as per national and international standards to the installation system (such as inhibitors, anti-freeze, pH regulator, lime and bacteria inhibitors, chemicals which are asserted to improve heat efficiency). Or else your device will be outside the guarantee scope.

GUARANTEE CONDITIONS



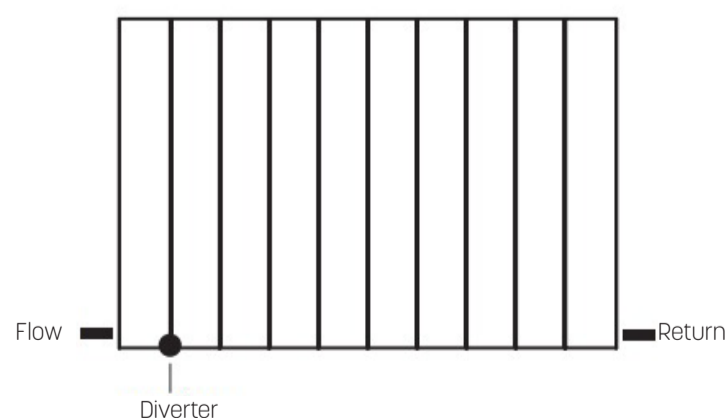



- Our heating systems have been produced as per TS EN 442, CE and UK standards. Our heating systems are under guarantee scope of 5 years against production and material failures when assembly, maintenance and usage rules are complied with.
- By getting approval for the guarantee certificate of your device from your seller, keep it during the guarantee period together with its invoice. Guarantee period starts on the date when invoiced product is delivered to the user.
- In addition to the conditions being stated on the usage instructions;
- Other than the conditions being specified on the instructions, failure notifications with reasons relating with assembly, usage, and maintenance are outside the guarantee scope.
- Defects and failures originating from parts and installment being connected to the device are outside the guarantee scope.
- Any damages occurring due to reasons such as falling, having dashes, being scratched or due to chemical reasons during the carriage, maintenance, assembly or usage of device are outside the guarantee scope.



* The diverter has been inserted into Galena radiators.

03

04

					
---	--	--	--	--	--

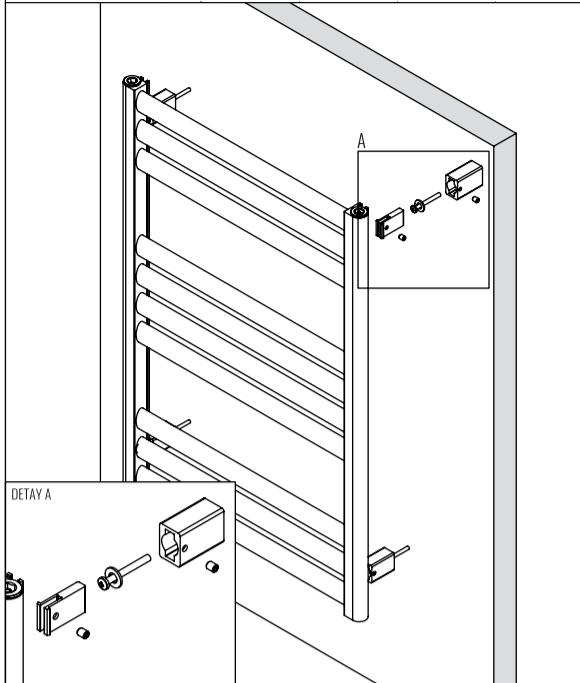

1 External connection apparatus

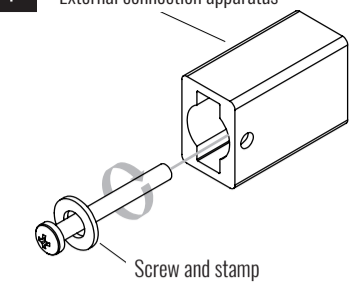

Screw and stamp

2

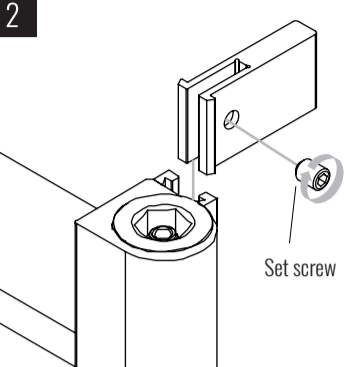

Set screw

3 External connection apparatus

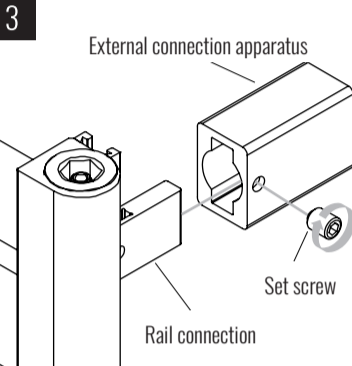

Set screw

Rail connection



7 By using the template at the back of product box, assemble the wall connection part on the area where you want to hang the product.

2 After placing the rail connections in the channel that is at the back side of product, fix them with set screw.

3 After repeating the same process for each one of 4 connection parts, by interlocking the part on the product and the parts on the wall, fix the product on the wall by using the second set screw.

DETAIL A

-Make sure that wall connections are safe to carry to product safely
-If water connection elements are compressed too much during assembly, damages causing water leakages can occur.
-Make sure that necessary precautions have been taken to avoid for the product to be damaged during carriage and assembly.

		
--	--	--

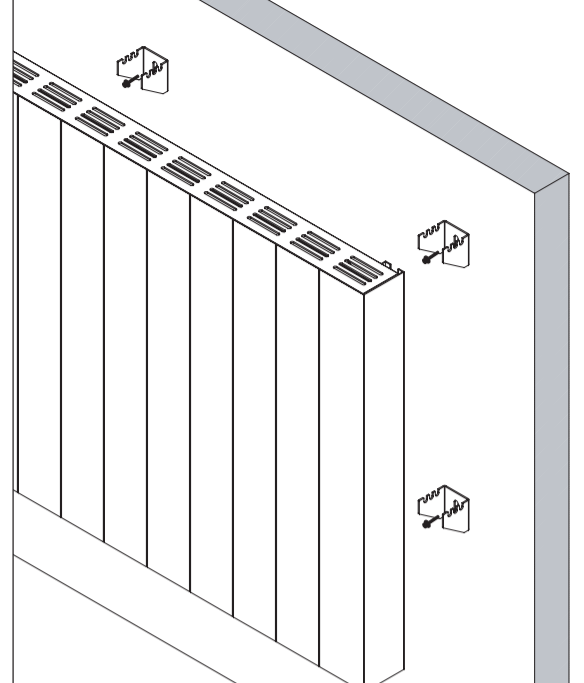

1

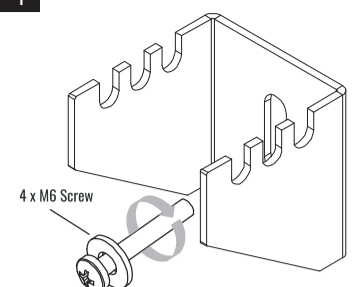

4 x M6 Screw

2

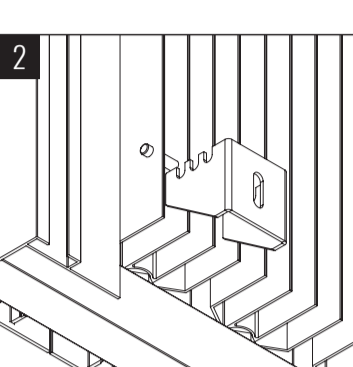

3

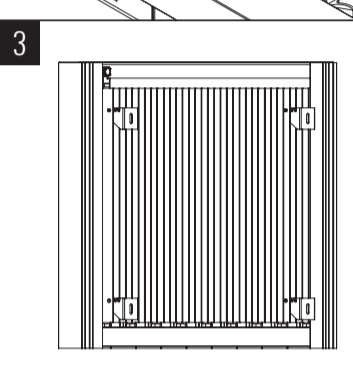

1 Wall mounting of the upper bracket.

2 Wall mounting of the lower bracket.

3 Let some angle the radiator and place it first on the lower bracket and then on the upper bracket.

1 Assemble the upper bracket parts on the area where you want to hang the product.

2 Assemble the lower bracket parts.

3 Take one tapped angle with lower brackets and bottom of product for placing to bottom side.

-Make sure that wall connections are safe to carry to product safely
-If water connection elements are compressed too much during assembly, damages causing water leakages can occur.
-Make sure that necessary precautions have been taken to avoid for the product to be damaged during carriage and assembly.

05

06

**5-YEAR WARRANTY AGAINST
MANUFACTURING AND MATERIAL
DEFECTS**

**5
YEAR WARRANTY**



TESTED PRODUCT

**UK UK
NI CA**

07

08