

Hungerford

Eastbury

**TECHNICAL INFORMATION**  
**STANDARD CONNECTIONS 1/2"**

**F** = Flow      **R** = Return  
**E** = Element position

Tube Diameter = 31.8mm



Showing position of electric and dual fuel element

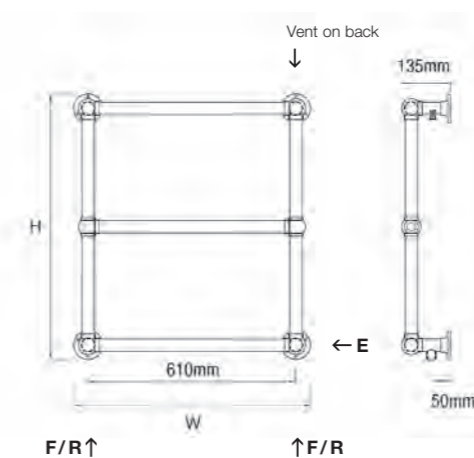

Hungerford

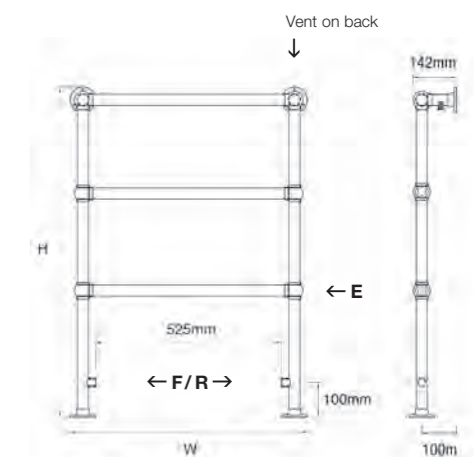

Eastbury

Model	Height (H) (mm)	Width (W) (mm)	Watts $\Delta t$ 50°C	Btu's $\Delta t$ 50°C	Electric Element Wattage	Chrome (inc VAT)	Weight (kgs)
<b>HUNGERFORD</b>							
Hungerford	685	685	137	467	150	£266.40	15
<b>EASTBURY</b>							
Eastbury	952	680	145	494	150	£323.00	16

\* Next working day delivery

VALVES & ACCESSORIES  
(Please see pages 138-148)

**ADDITIONAL EXTRAS:**

- ELECTRIC OPTION WITH ESSENTIAL ELEMENT + £114.00
- DUAL FUEL OPTION WITH ESSENTIAL ELEMENT + £66.00
- ELECTRIC OPTION WITH MEG THERMOSTATIC ELEMENT + £210.00
- DUAL FUEL OPTION WITH MEG THERMOSTATIC ELEMENT + £126.00

AVAILABLE IN THE FOLLOWING FINISHES:

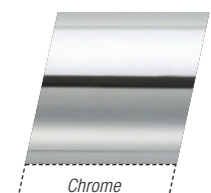

Chrome

# ESSENTIAL

## TRADITIONAL TOWEL RAILS